



ICEBERG - REFRIGERATED SEMI-TRAILER INTRODUCTION AND USER MANUAL





ABOUT US

Prioritizing the provision of the most suitable solutions by identifying end-user needs through its ATP-compliant, FRC, and HACCP-certified production, BRF has focused on refrigerated trailer manufacturing since its establishment.

Serving its customers with 6 different products, namely:

- ❖ Standard Refrigerated Trailer
- ❖ Meat Hanging Refrigerated Trailer
- ❖ Double-Deck Refrigerated Trailer
- ❖ Curtainsider Refrigerated Trailer
- ❖ Multi-Door Refrigerated Trailer
- ❖ Refrigerated Truck Body

BRF trailer panels are "sandwich" panels made of high-density polyurethane material. They are manufactured between fiberglass GRP sheets using a heated high-pressure pressing method with the wet-on-wet system. High-quality, high-thermal-insulated, impact-resistant, and low-maintenance panels, along with the vehicle's lightweight structure, are the reasons why our customers prefer BRF.

Despite focusing on medium-scale boutique production, it has become well-known in the Refrigerated Trailer sector in a short time thanks to the importance it attaches to quality and its determination to achieve the difficult, and it has never compromised on these principles since the moment it was founded.



Dear Customer,

This user manual will help you get to know your BRF product, benefit from its intended use possibilities, and extend the service life of the vehicle. The manual contains important information on how to operate the product safely, properly, and economically. Adhering to these instructions will help prevent hazards, reduce malfunctions and downtime, and increase the reliability and lifespan of the product.

Read the user manual carefully and follow the instructions strictly. It must be ensured that all personnel required to work on the vehicle have access to the user manual at all times. The user manual should always be kept in the glove box of the towing vehicle's driver cabin.

Copyright

Within the context of the law against unfair competition, this user manual constitutes a document. Accordingly, the owner of the copyrights is BRF.

This user manual contains texts and drawings that, without the explicit consent of BRF, must not be:

- Reproduced,
- Distributed, or
- Shared in any other way, either in whole or in part.

Any violation will result in a claim for damages.

TABLE OF CONTENTS

1- Technical Specifications	
2- Basic Tire Maintenance and Information	6
3- Maintenance of the Refrigerated Body	7
	20
4- Electrical System Diagram	26
5- Axle and Suspension Maintenance	31
6- Certificates and Production Documents	50
a) ATP - FRC Certificate	50
b) HACCP - Food Safety Certificate	54
c) ISO-9001:2015	55
d) Sample Certificate of Conformity	56
6- Warranty Agreement	60
7- Authorized Services and Contact Numbers	61

1- TECHNICAL SPECIFICATIONS

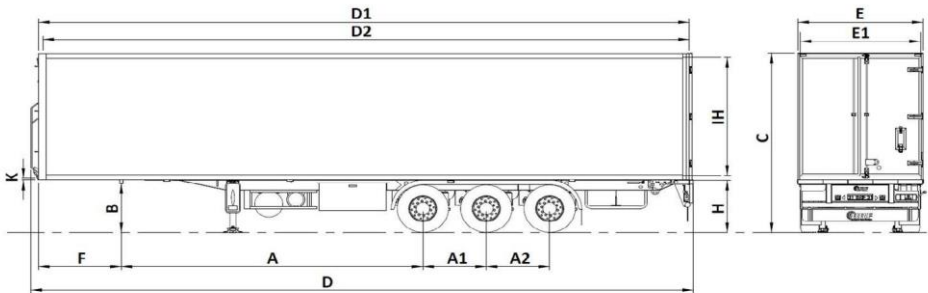

Standard – Double Deck – Meet Hooks

Dimensions (mm)	Axle center	(A+A1)	7600
	Distance between two axles	(A1/A2)	1320
	Total length	(D)	13815
	Box length	(D1)	13600
	Loading area length	(D2)	13300
	Total width	(E)	2605
	Loading area width	(E1)	2465
	Total height	(C)	4020
	Loading area height	(IH)	2650
	Driving height	(B/H)	1150
Gooseneck	(K)	10	
Front plate length	(F)	1600	

Masses (kg)	Fifth wheel Kingpin load		11500
	Technically permissible Kingpin load		15000
	Total axle load	24000 (each axle load 8000)	
	Technically permissible axle load	27000 (each axle load 9000)	
	Permissible laden weight		35500
	Technically permissible laden weight		42000
	Actual masses (Excluding cooling unit)		
	*Standard		7600
*Meat Hanging		8510	
*Double Deck		7850	

2- BASIC TIRE MAINTENANCE AND INFORMATION

1. Tire Components

Radial Ply Tire

In radial tires, the casing plies form a 90-degree angle to the circumference of the tire. Additionally, the parts of the tire that come into contact with the road surface are reinforced with a steel-cord structure known as the "belt."

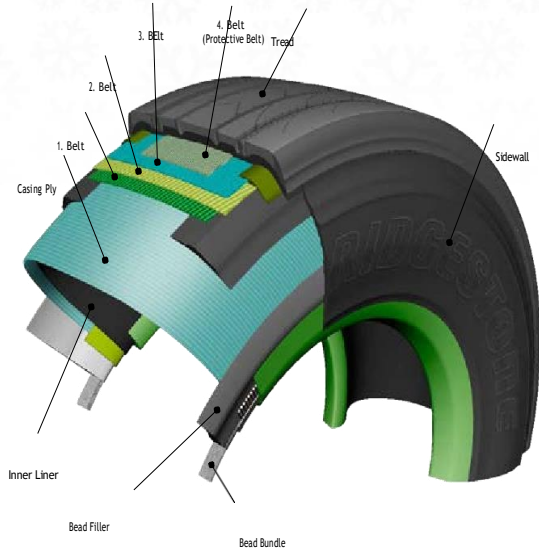

2. Tire Size Designation

315	Section width (mm)
80	Aspect ratio
R	Tire structure code (radial)
22.5	Rim diameter (inches)
154/150	Load index (single/dual use)
K	Speed symbol

3. Tire Definitions

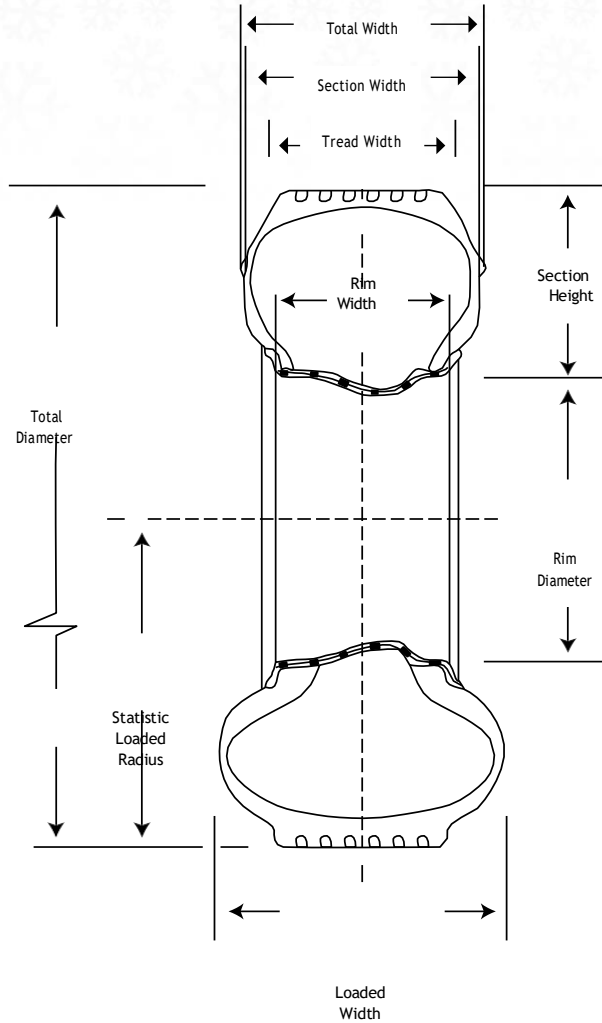

1. Manufacturer Brand Name

2. Pattern Name

3. Size Information

245= Tire tread with (sidewall to sidewall - mm)

70= Aspect ratio (ratio of height to width)

4. Service Information

136= Load index for single use 134= Load index for dual use

M= Speed symbol

5. ECR117 designation

E4 - 028518 S2WR2

E= Compliance of the tire with ECR117 regulation

4= Approval number of the country where it was obtained

8518= R117 number



S2 = Indicates the level at which the tire meets the regulation limit.

W = Indicates that the tire meets the regulation wet grip test limit.

R2 = Indicates that the tire meets the regulation maximum rolling resistance level.

6. Max. load and pressure information according to US Standards

7. Load range class according to US standards

8. DOT (Date of manufacture)

9. Regroovable (Indicates that the tire is suitable for regrooving.)

10. JATMA size code.

11. Country of manufacture

12. Safety warnings

13. Tubeless (Indicates that the tire is used without an inner tube.)

14. M+S marking

15. Snowflake (Alpine) marking

5. Load Index

The load index is a numerical code that specifies the maximum load a tire can carry at the speeds and under the service conditions specified by the tire manufacturer.

5.1 Loaded Index and Carrying Capacity

Load Index	Kilograms	Load Index	Kilograms	Load Index	Kilograms
100	800	134	2,120	168	5,600
101	825	135	2,180	169	5,800
102	850	136	2,240	170	6,000
103	875	137	2,300	171	6,150
104	900	138	2,360	172	6,300
105	925	139	2,430	173	6,500
106	950	140	2,500	174	6,700
107	975	141	2,575	175	6,900
108	1,000	142	2,650	176	7,100
109	1,030	143	2,725	177	7,300
110	1,060	144	2,800	178	7,500
111	1,090	145	2,900	179	7,750
112	1,120	146	3,000	180	8,000
113	1,150	147	3,075	181	8,250
114	1,180	148	3,150	182	8,500
115	1,215	149	3,250	183	8,750
116	1,250	150	3,350	184	9,000
117	1,285	151	3,450	185	9,250
118	1,320	152	3,550	186	9,500
119	1,360	153	3,650	187	9,750
120	1,400	154	3,750	188	10,000
121	1,450	155	3,875	189	10,300
122	1,500	156	4,000	190	10,600
123	1,550	157	4,125	191	10,900
124	1,600	158	4,250	192	11,200
125	1,650	159	4,375	193	11,500
126	1,700	160	4,500	194	11,800
127	1,750	161	4,625	195	12,150
128	1,800	162	4,750	196	12,500
129	1,850	163	4,875	197	12,850
130	1,900	164	5,000	198	13,200
131	1,960	165	5,150	199	13,600
132	2,000	166	5,300	-	-
133	2,060	167	5,450	-	-

5.2 Variation in Carrying Capacity Based on Speed and Inflation Pressure

Speed (km/h)	Change in Load Carrying Capacity (%)						Inflation Pressure Adjustment (%)
	Speed Symbol						
	F	G	J	K	L	M	
Statik	+150.0	+150.0	+150.0	+150.0	+150.0	+150.0	+40
5	+110.0	+110.0	+110.0	+110.0	+110.0	+110.0	+40
10	+80.0	+80.0	+80.0	+80.0	+80.0	+80.0	+30
15	+65.0	+65.0	+65.0	+65.0	+65.0	+65.0	+25
20	+50.0	+50.0	+50.0	+50.0	+50.0	+50.0	+21
25	+35.0	+35.0	+35.0	+35.0	+35.0	+35.0	+17
30	+25.0	+25.0	+25.0	+25.0	+25.0	+25.0	+13
35	+19.0	+19.0	+19.0	+19.0	+19.0	+19.0	+11
40	+15.0	+15.0	+15.0	+15.0	+15.0	+15.0	+10
45	+13.0	+13.0	+13.0	+13.0	+13.0	+13.0	+9
50	+12.0	+12.0	+12.0	+12.0	+12.0	+12.0	+8
55	+11.0	+11.0	+11.0	+11.0	+11.0	+11.0	+7
60**	+10.0	+10.0	+10.0	**+10.0	+10.0	+10.0	+6
65	+7.5	+8.5	+8.5	+8.5	+8.5	+8.5	+4
70	+5.0	+7.0	+7.0	+7.0	+7.0	+7.0	+2
75	+2.5	+5.5	+5.5	+5.5	+5.5	+5.5	+1
80	0	+4.0	+4.0	+4.0	+4.0	+4.0	0
85	-	+2.0	+3.0	+3.0	+3.0	+3.0	0
90	-	0	+2.0	+2.0	+2.0	+2.0	0
95	-	-	+1.0	+1.0	+1.0	+1.0	0
100	-	-	0	0	0	0	0
110	-	-	-	0	0	0	0
120	-	-	-	-	0	0	0
130	-	-	-	-	-	0	0

*The amount of increase in the absence of any special agreement with the tire manufacturer.

**To explain the table above in more detail; for a 315/80R22.5 154/150K tire in single use, the carrying capacity of a single tire is 154, which equals 3,750 kg. The "K" indicates a speed limit of 110 km/h. At the "K" speed symbol, the carrying capacity remains 3,750 kg. However, if we reduce the speed to 60 km/h, we can increase our load by 10%.

6. Speed Symbol

The speed symbol is a code that indicates the maximum speed a tire can reach under the service conditions and load specified by the tire manufacturer.

Speed Symbol	Speed (km/h)	Speed Symbol	Speed (km/h)	Speed Symbol	Speed (km/h)
B	50	J	100	Q	160
C	60	K	110	R	170
D	65	L	120	S	180
E	70	M	130	T	190
F	80	N	140	-	-
G	90	P	150	-	-

7. Pressure Units Conversion Table

1050 kPa	Bar	lb/in(P.S.I.)*	kg/cm*
100	1.0	15	1.0
150	1.5	22	1.5
200	2.0	29	2.0
250	2.5	36	2.6
300	3.0	44	3.1
350	3.5	51	3.6
400	4.0	58	4.1
450	4.5	65	4.6
500	5.0	73	5.1
550	5.5	80	5.6
600	6.0	87	6.1
650	6.5	94	6.6
700	7.0	102	7.1
750	7.5	109	7.7
800	8.0	116	8.2
850	8.5	123	8.7
900	9.0	131	9.2
950	9.5	138	9.7
1000	10.0	145	10.5
1050	10.5	152	10.7

* P.S.I. and kg/cm² values have been rounded to the nearest practical values.

8. FRT (Free Rolling Tire)

8.1 Definition

On trucks and tractor units, tires with the FRT (Free Rolling Tire) marking must only be used on trailers or free-rolling axles; they must strictly never be used on the front (steering) axle or the drive axle.

8.2 General Approach

Brisa recommends that tires marked "FRT" (Free Rolling Tire) should only be used on trailer and free-rolling axles, and should not be used on front (steering) or drive axles. Neither Brisa nor any of its affiliates shall be held liable for any damage or loss resulting from the use of the tire on front or drive axles, despite Brisa's warning.

9. M+S and Snowflake Marking

9.1 Winter Tire Usage Regulation

Whether registered in our country or not, vehicles used for passenger or freight transport on intercity highways are required to use winter tires during the four-month period between December 1st and April 1st of the following year.

During the period when winter tires are mandatory, it is required for the sidewalls of the winter tires to have the (M+S) marking, or the (M+S) marking together with the Snowflake (3PMSF) symbol, or only the Snowflake (3PMSF) symbol.

The tread depth of winter tires on trucks, tractors, tankers, and buses cannot be less than 4 mm. Tread depth is measured from the grooves closest to the center of the tire tread. Additionally, any tires installed to replace those changed during transit must also be winter tires. Carrying or using anti-skid chains is not sufficient; the tires themselves must be winter tires..

9.2 M+S Marking Definition

The Mud & Snow performance is superior compared to tires without the M+S marking.

9.3 Snowflake (3PMSF) Marking Definition

All of our tires carrying the winter marking indicate that they have passed the snow acceleration test under winter conditions as defined by UNECE..

10. Tire Matching

BRF recommends using the same brand and pattern across the entire axle, ensuring that the tread depth difference does not exceed 3 mm.

- 1- Different patterns should not be used on the same axle.
- 2- There should not be a tread depth difference exceeding 3 mm between the tires used on the same axle.
- 3- In dual (twin) fitment, all tires on the same axle must have the same brand of casing (carcass).
- 4- All tires on the same axle must have the same construction structure.

11. Maintenance and Repair

11.1 Mounting and Dismounting

11.1.1 General

Tire replacement is a dangerous operation and must be performed by trained personnel according to standard procedures using appropriate equipment.

11.1.2 Deflation and Dismounting

1. Always check whether the tires have been mounted correctly.
2. Deflate the tire before dismounting.
3. Never lean against the tire while deflating it.
4. Strictly never attempt to unseat the bead on a tire that is still pressurized.
5. Never strike the tire or the rim with a hammer.
6. Always follow the mounting and dismounting procedures recommended by the RMA (Rubber Manufacturers Association) or ETRTO (European Tyre and Rim Technical Organisation)..

11.1.3 Mounting and Tire Inflation

1. Always check the inside of the tire for cuts, exposed cords, or any embedded foreign objects.
2. Always inspect the interior of the tire for dirt, liquids, or foreign materials.
3. Use only approved lubricants designated for tire mounting. Never use antifreeze, silicone, or petroleum-based lubricants.
4. Strictly never strike the tire or the rim with a hammer.
5. Before inflation, ensure that the tire is properly seated on the rim.
6. Never exceed 3 p.s.i. of air pressure before placing the tire/rim assembly into a safety cage.
7. Always inflate the tire inside a tire inflation cage..
8. Use an extension hose with a gauge and clip-on chuck to ensure the operator stays at a safe distance during inflation.
9. Carefully check the valve core to ensure air safety. Replace any damaged or leaking valve cores.
10. Always inflate tires to the cold operating pressure recommended by the tire manufacturers.

11.2 Tires and Rims

1. Always select the correct tire size and construction to match the manufacturer's rim.
2. Do not mount or use a damaged rim.
3. Always inspect the rim and clean it if any burrs are present.
4. Never perform reworking, welding, heating, or brazing on the rim.
5. Always ensure that the rim components are properly structured and compatible.
6. Do not use an unapproved rim or unapproved rim components.
7. Always use an approved rim during mounting.

11.3 Inflation Pressure

1. Most tire damage occurs due to incorrect inflation pressure. Truck and bus tires must be inflated according to the load they carry.
2. Check tire pressure at least once a week using a calibrated pressure gauge.
3. Tire pressure checks must be performed when the tires are cold.
4. The valve cap acts as an additional air seal and must always be on the valve.
5. Inflation pressure can increase by as much as 20% (10 to 15 p.s.i.) during operation, as permitted by the tire design. Therefore, never adjust the inflation pressure while the tire is hot; wait for the tire to cool down.
6. Do not run the vehicle if a tire has low pressure or is flat.
7. If a hot tire has a pressure lower than the recommended cold inflation pressure, it is considered under-inflated..
8. Incorrect inflation pressure causes irregular tread wear. To minimize irregular wear, Brisa recommends the following:
 - a. Always inflate tires according to the recommended cold pressures.
 - b. If excessive irregular wear exists despite correct inflation pressure, please consult Brisa's technical Field Engineering team..

11.4 Rotation

11.4.1 General

Tire rotation is a practical tool for reducing tire costs. Rotation increases tire life by preventing irregular wear.

1. Rotating the tire on the rim while in the same position:

Counteracts one-sided shoulder wear and is also useful in applications where the tire is exposed to a greater amount of sidewall wear or general wear.

Note: The root cause of the irregular wear must be checked..

2. Swapping tires side-to-side on the same axle:

In city use specifically, this balances sidewall wear caused by road camber or contact with curbs, depending on the characteristics of the route..

3. Flipping tires (Inside-Out):

Balances the wear between dual (twin) tires and moves the sidewall that was facing outward to the inward position..

4. Moving tires from one axle to another:

For 6x2 trucks, this extends tire life in cases of high wear rates occurring on the front axles (1st and 2nd axles) due to differences in cornering forces.

5. Rotating trailer tires (1st axle to 3rd, 3rd to 2nd, 2nd to 1st):

Maximizes tire life by increasing resistance to irregular wear across all trailer axles.

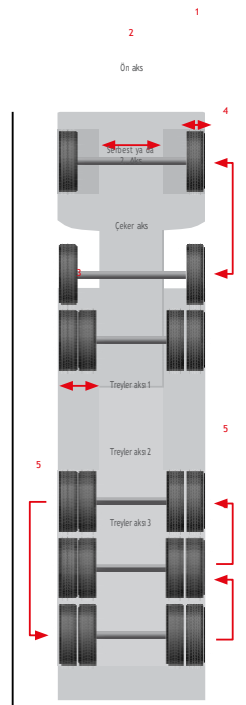

11.5 Damage

1. If action is not taken quickly, a damaged tire can also cause damage to the vehicle.
2. Tire damage must be repaired as soon as possible to prevent further deterioration of the tire structure.

11.6 Minimum Tread Depth

For the trailer tire group, BRF recommends removal at 3 mm for summer use and 4 mm for winter use. However, minimum legal tread depths are established in different countries, and each country's own regulations or fleet agreement specifications must be followed. To obtain maximum performance and increase retreadability under different operating conditions, tires are removed when tread depth is above 3 mm in summer and 4 mm in winter to improve retreading performance.

11.7 Regrooving

To protect the tire casing, extending beyond the original pattern depth is permitted, provided sufficient rubber remains. Before regrooving, check the sidewall to see if it is marked "Regroovable."

Note: For more information, please consult the Brisa Field Engineering department.

11.8 Repair and Retreading

All casings in trailer tires are repairable and/or retreadable. The decision on a tire's retreadability must be made after an inspection by a specialist. Brisa recommends Bandag brand cold tread retreading, known for its high retreading performance and quality.

11.9 Marking

The marking location on a tire must be chosen carefully.

1. The most suitable location for marking is within the white area shown in the figure below, between the rim line and the size panel line..

2. The marking depth in the region mentioned above (item 1) must be a maximum of 0.5 mm.
3. For radial tires, do not apply marking to the critical flexing areas located near the maximum section width..

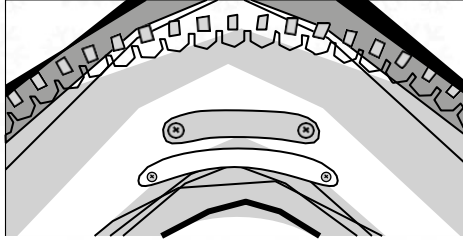

11.10 Storage

1. Considerations for Long-Term Tire Storage:

- Do not store tires in direct sunlight or near heat sources.
- Keep tires away from ozone-emitting motors and generators.
- Keep tires away from oils and chemicals.

2. To prevent permanent deformation of horizontally stacked tires, the height of the tires stacked on top of each other must not exceed 1.5 meters.

3. For steel radial tires, excessive moisture permeability can lead to the deterioration of the tire structure and potentially cause tire failures.

Our Recommendations:

1. Store unmounted tires indoors in a dry place, away from moisture.
2. Before mounting a tire on a rim, ensure that the inner surface of the tire, the inner tube, the rim, or the inner surface of the rim is completely dry and clean.
3. Keep the compressors used for inflating tires away from moisture to prevent internal damage to the tire structure.

12. Spacing Between Tires in Dual Fitment

12.1 Recommended Minimum Distance Between Tires in Dual Fitment on 5° Drop-Center Rims

Nominal Tire Section	Rim Width Code	Recommended Minimum Distance (mm)
125/90	3.00	139
145	3.50	145
155	4.00	167
165	4.50	181
175	4.50	192
185	5.00	205
195	5.50	216
205	5.50	228
215	6.00	239
225	6.00	251
235	6.50	262
255	7.00	274
5.60	4.00	172
6.70	5.00	209

The values above are for normal highway use. In special circumstances, the tire manufacturer should be consulted.

3- REFRIGERATED BODY MAINTENANCE

Rear Doors:

Two-wing doors that open 270 degrees on both sides provide ease of loading and unloading. The 85 mm thick gaskets surrounding the doors ensure full sealing. The door opening and locking mechanisms are designed to be user-friendly for the driver.



Opening and Closing the Rear Door;

- Opening/Closing Sequence: Opening always begins with the right door, and closing always begins with the left door.
- Unlocking: As seen in the figure, press the latch in the center of the lock inward, then slowly pull the lock handle toward you.
- Releasing the Door: Rotate the lock handles to release the upper and lower locking cams from their sockets. Once the door is open, release the lock handles.



Caution: When opening the doors, always consider the possibility that the transported load may be leaning against the door and could fall out.

Securing the Doors

Fastening: To prevent damage caused by doors striking the side walls or the door frame, secure the doors using the door retainers located on the rear side walls, as shown in the image.

Safety: When the doors are open, the door retainer prevents severe impacts and serious injuries caused by wind. Therefore, never forget to secure the doors with the retainers.

Closing: To close the doors, follow the same procedure in reverse.

- Check that the doors are closed properly and that the upper and lower cams are fully seated in their sockets. Never set off on the road with a vehicle whose doors are not securely closed..

Body-Chassis Connection;

The body (box) is connected to the trailer chassis using mounting brackets and bolts.

Inspection Period: Check the tightness of these connections daily for the first 5,000 km, and monthly thereafter.

Tightening Torque: The bolts should be torqued to 70 Nm.

To transfer fuel from the fuel tank, you must provide air to the tank with the help of the valve located on the tank. To ensure this, first connect the fuel tanks to each other with a hose and then open the red valve on the trailer tank and provide air to the tank for about 40 seconds. Then, you can start the transfer process by turning the blue valve. When the transfer process is finished, finally we need to discharge the air remaining in the tank with the drain valve.

Loading;

Do not allow your vehicle to be loaded beyond its carrying capacity.

-Ensure the load is distributed evenly on the vehicle.

-Take the necessary precautions to ensure the load stands securely inside the vehicle and does not move.

-Be careful when opening the doors and pay attention not to damage the gaskets.

-If you use a forklift for loading, take care that the forklift forks do not damage the vehicle by hitting the walls or doors.

-In order to get the highest performance from the vehicles and the cooling units; the minimum spaces specified below must be left around the load..

Between the load and the ceiling: 180 mm.

Between the load and the rear door: 90 mm.

Between the load and the floor: 90 mm.

Appropriate gaps should be left between the load and the walls depending on the condition of the load.

Cooling Equipment:

The initial operation and routine maintenance of cooling units must be carried out in accordance with the manufacturer's instructions specified in the cooling catalogs.

The coolers operate fully automatically from the initial start until the moment of stopping. During this operation, they enter defrost mode on their own.

In the event that the cooling unit breaks down and stops for any reason, your vehicle will continue to preserve the cold air inside for a certain period, depending on the outside temperature. In such a case, if the time required for the repair of the cooler is short enough not to require a transfer of the load to another vehicle, parking the vehicle in a shaded, cool spot and keeping it in the same place until the cooler is restarted will better protect the load during this time.

If excessive and continuous operation is detected in the cooling device and the interior temperature of the body remains normal at the desired level;

- (a) Air ingress may occur as a result of leakage from the gaskets on the doors.
- (b) The outside air temperature may have risen excessively.
- (c) Insulation efficiency may have decreased due to aging.
- (d) The requested interior temperature may be excessive relative to the cooling capacity.
- (e) Air circulation around the load may be insufficient.

Leave as much time as possible between the operations of the cooling device to protect the unit. In cases where the vehicle is parked empty, always leave the doors open.

Loading:

- Do not allow your vehicle to carry more than its load-carrying capacity.
- Ensure the load is distributed evenly on the vehicle.
- Take the necessary precautions with load retainers and tensioner straps (ratchet straps) to ensure the load stands securely inside the vehicle and does not move.
- If a portion of the load is unloaded during travel and the journey will continue with a partial load, rearrange it by considering the load distribution and place the loads toward the rear door to prevent air loss.
- Open the doors carefully and try not to damage the gaskets.
- If you use a forklift for loading, take care that the forklift forks do not damage the doors and walls by hitting them..

Cooling Units

Causes of Malfunctions and Troubleshooting:

Malfunction	Cause	Remedy
Cooling engine stops and does not restart.	The fuel in the cooling engine tank has run out.	Check for fuel leaks. Fill the tank with fuel.
	The engine is faulty.	Visit the nearest manufacturer's service center.
	The battery is weak.	Replace the battery.
Electric motor does not work.	No energy is reaching the motor.	Check the unit fuse and the main power cable.
	The motor is faulty.	Visit the nearest manufacturer's service center.
Visit the nearest manufacturer's service center.	The interior is iced up.	Set the unit to defrost.
	The thermostat is faulty.	Visit the nearest manufacturer's service center.

GENERAL INSTRUCTIONS

- Be careful when opening and closing the doors and pay attention not to damage the gaskets and EPDM seals.
- Exercise caution when opening the doors against the possibility that the load may have shifted during the journey.
- Never set off on the road with a vehicle whose doors are not properly closed.
- After the vehicle is loaded, ensure your load is properly tied and secured to prevent it from sliding and damaging the wall panels or the rear door; do not allow the load to shift.
- Take care that your load/pallets do not damage the walls by hitting them during loading.
- In cases where loading is performed with a forklift, ensure that the forklift forks do not strike the vehicle walls, doors, or side panels.
- Do not allow overloading, considering the load-carrying capacity of the vehicle. Depending on the nature of the load, the vehicle may be completely full before reaching the maximum allowable weight, or the loading capacity may be exceeded before the vehicle is completely full.
- Ensure the even distribution of the load on the vehicle.
- If a portion of the load is unloaded during the journey and you continue with a partial load, rearrange the load distribution considering this situation and ensure that the vehicle can travel balanced in the partially loaded state.

ELECTRICAL SYSTEM

Electrical Connection of the Refrigerated Box

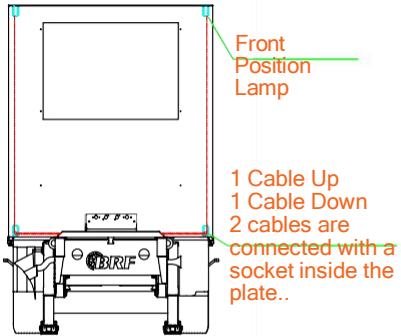
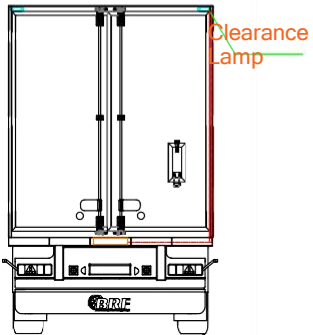
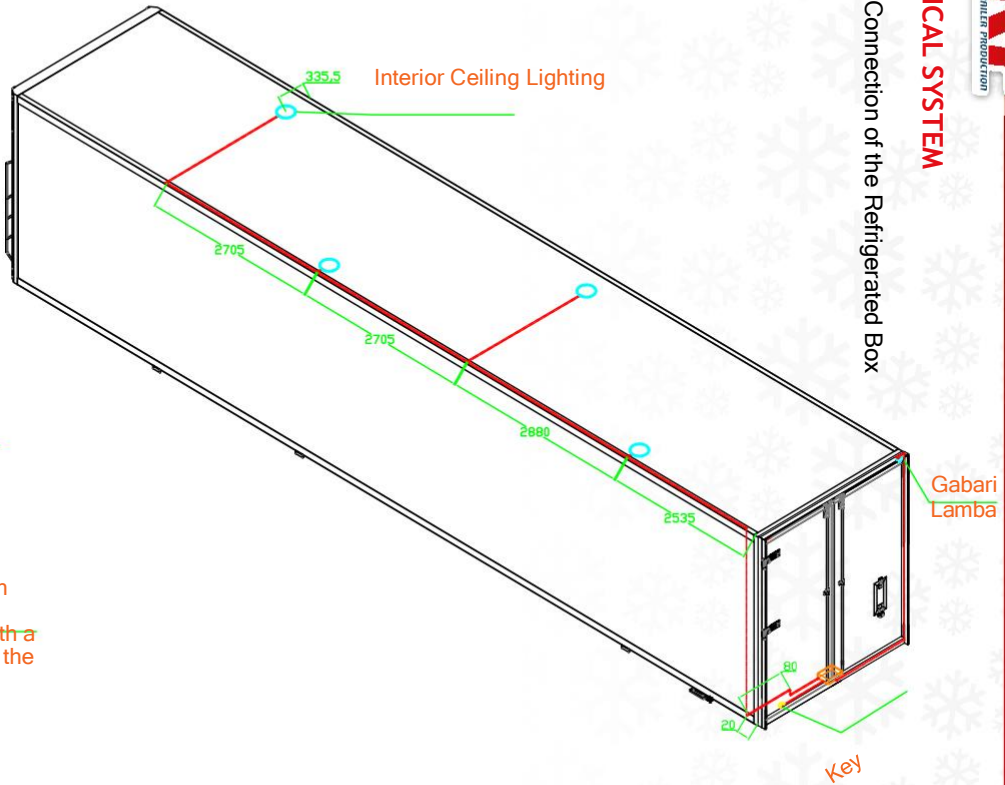

Main Chassis Electrical Connection Diagram

SALES

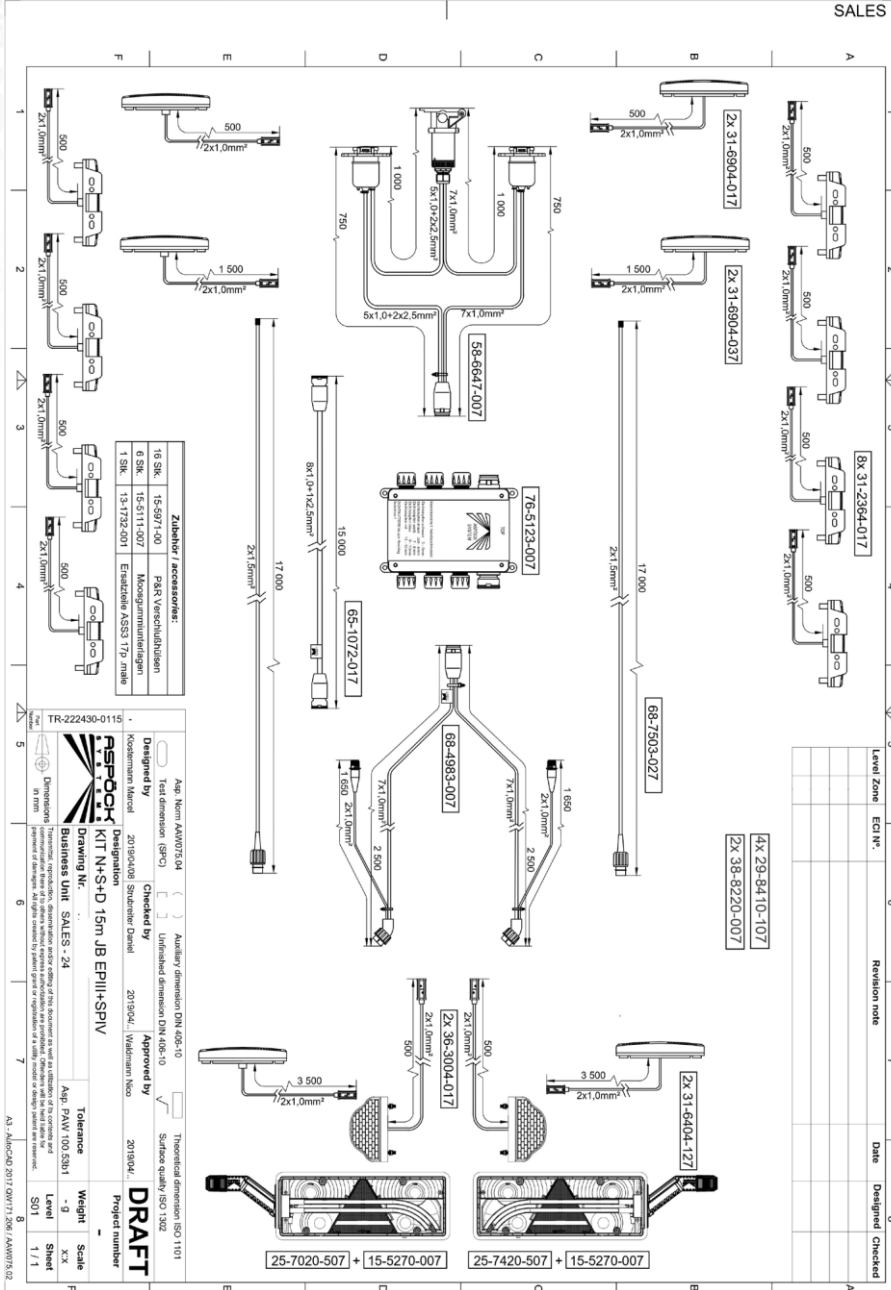

Spare Parts Electrical System and Codes

TR-222430-0115D

	ASPÖCK PART NO	DESCRIPTION	AMOUNT
1	25-7020-507	TAIL LIGHT WITH HORN EURO III LEFT	1
2	25-7420-507	TAIL LIGHT WITH HORN EURO III RIGHT	1
3	36-3004-017	LICENSE PLATE LAMP REGPOINT AMP 0.5 M	2
4	76-5123-007	JUNCTION BOX STANDARD+ ASS3 X2 WIRELESS	1
5	68-4983-007	REAR CABLE, TAIL+PLATE LIGHTING+2 SIDE PARK	1
6	68-7503-027	SIDE PARK CABLE 2X17 M SET	1
7	31-2364-037	SIDE PARK LAMP LED FLATPOINT II - 1.5 M	8
8	31-6904-037	POSITION LAMP FRONT-LED-WHITE-1.5 M	2
9	31-6904-057	POSITION LAMP FRONT-LED-WHITE-3.5 M	2
10	31-6404-127	POSITION LAMP REAR CLEARANCE RED 3.5 M	2
11	38-8220-007	WORKING LAMP LED 1500/60	2
12	58-6647-007	CONNECTOR FRONT CONNECTION 2x7+15P-0.6 M (N+S 15P)	1
13	65-1072-017	MAIN HARNESS CABLE 15 M X 9 CORE WITH 17 PIN SOCKET	1
14	15-5270-007	TAIL LIGHT GUARD (SMALL)	2
15	15-5971-007	CLIP P&R-CABLE COMPRESSION 24V	16
16	15-5111-007	PAD-POSITION LAMP FLATPOINT (RUBBER GASKET)	6
17	13-1732-001	SOCKET CONNECTION KIT ASS3 17 PIN MALE	1
18	29-8410-107	CEILING LAMP ROUND 20 LED 480 LM (OPEN END)	4

Rear Tail Light Drawing

LINKS / LEFT

EUROPOINT III

mit SML +SP IV
with SML + SP IV

IP56K

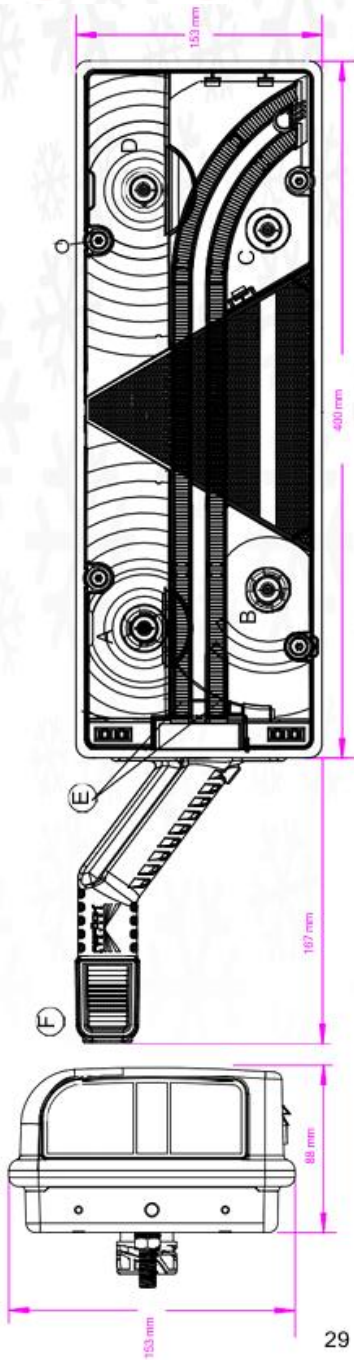

	Funktion	function
A	Blinker	flasher
B	Bremse	brake
C	Nebelschl.	fog
D	Rückfahrschl.	reverse
E	Standlicht - Light guide	rear light - Light guide
F	Standlicht - Rechts LED	rear light - right LED

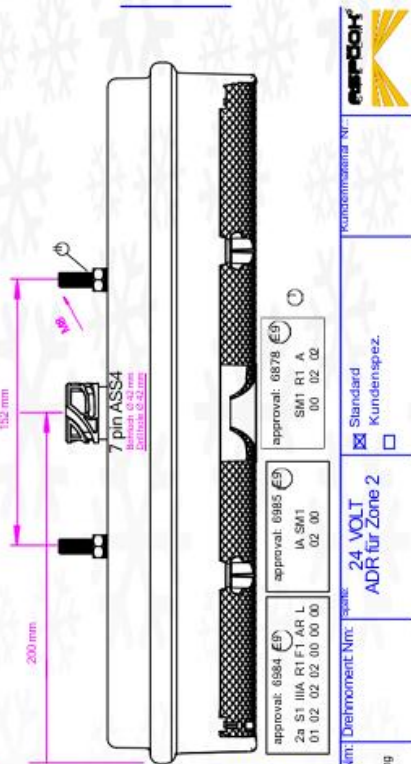

1	130820	GB	Homologation number updated
Rev. Nr.	Datum	Name	Änderung
121030	TG		Material-Nr. 25-7020-507
Freigabe			
Prüfart.			

approval: 6584	approval: 6985	approval: 6878
2a S1 IIIA E1 E1 A9 L	IA SMI	SM1 E1 A
01 02 02 02 00 00 00	02 00	00 02 02
Drehmoment Nm: <input checked="" type="checkbox"/> Standard <input type="checkbox"/> Kundenspez.		
24 VOLT ADR für Zone 2		
Drehmoment Nm: <input checked="" type="checkbox"/> Standard <input type="checkbox"/> Kundenspez.		
Lichtschabe/lense max 1,3Nm <input checked="" type="checkbox"/> Gehäuse Thousing 5,5 - 6,0Nm		
Drehmoment Nm: <input checked="" type="checkbox"/> Standard <input type="checkbox"/> Kundenspez.		
Material-Nr. 25-7020-507		

5- AXLE AND SUSPENSION MAINTENANCE

Axle data/ Identification of the axle The exact type definition of the product must be kept ready when ordering spare parts. The 11-digit serial number (Serial-No.) is located on the type label.

SAF-HOLLAND GMBH D-63866 BESSENBACH • GERMANY		SAF Holland	
Version B9-22K01	Serial No. 11 09 156 0020		
Type SBK2243-11S	Ident No. 347 96 21 7 49 01		
Test Report 36110303	Perm. axle cap stat. 9000 kg		
Made in Germany	V max. 105 km/h		
AN 3335528		SN 11091560020	

AS-0027

Position of the Type Label



AS-0002

Şek. 2 · INTRA Tipi, Havalı Süspansiyon Sistemlerinde tip etiketinin pozisyonu

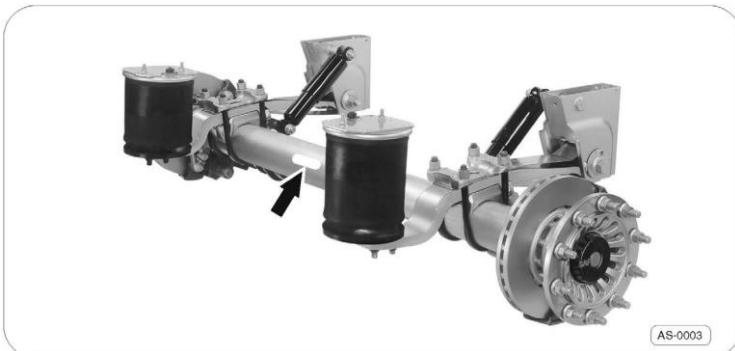

AS-0003

Şek. 3 · MODUL Tipi, Havalı Süspansiyon Sistemlerinde tip etiketinin pozisyonu ve serbest

Identification in Case of Absence of the Type Label

The axle serial number is located on top of the axle head on the right side in the direction of travel.

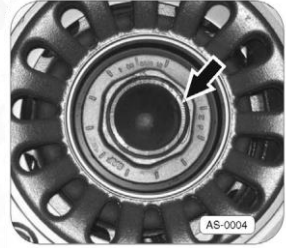

Şek. 4 - Sağ aks başı: Seri No:

The following field can be used to enter data for ordering original spare parts from SAF-HOLLAND.

	Kiml. No:	Seri No:
1. Aks		
2. Aks		
3. Aks		
4. Aks		
5. Aks		

Ordering Spare Parts

When ordering original spare parts from authorized services, attention should be paid to the assembly group of the relevant product.

Non-original (aftermarket) products have a shorter lifespan and negatively affect the product's function. Aftermarket products harbor risks and dangers that cannot be foreseen by the manufacturer. Beyond this, they also increase maintenance costs. A widespread service network consisting of manufacturer partner enterprises provides services for the technical maintenance of axle products and for keeping parts ready (see the last page of the manual). You can find further information on how to identify spare parts in the Aftersales section on our homepage at

www.safholland.com.

Instant updates will be published on the internet at www.safholland.com.

General Information

Liability

In principle, SAF-HOLLAND's "General Terms of Delivery and Working Conditions" apply. SAF-HOLLAND does not accept liability claims arising from damage to persons or property due to one or more of the following reasons:

- Improper use of the product (Page 7).
- Failure to observe the operating manual and the safety warnings contained therein.
- Unauthorized structural changes to the product.
- Inadequate maintenance of parts subject to wear (Page 10).
- Repair work not performed in accordance with the rules and on time (Page 10).
- Use of parts other than original SAF-HOLLAND spare parts (Page 5).
- Use of damaged parts.
- Disaster situations caused by external factors and force majeure.

Warranties and General Working Conditions

Explanations regarding valid warranties and general terms of delivery and working conditions (AGB) are available in the Sales section on our homepage at www.safholland.com.

Environmental Protection

All structural components, auxiliary materials, and operating substances used in the maintenance and repair of the product must be disposed of in an environmentally friendly manner.

Recyclable structural components must be cleaned of oil and lubricants and reintegrated into the recyclable material cycle. During this process, the disposal instructions for the relevant auxiliary and operating materials, as well as national legislation or local regulations, must be taken into account. Ensure that these are strictly read and observed before starting any work on the product.

Target Group

The operating manual of the product is intended solely for the use of the operator or persons authorized and informed by them.

The operator must ensure that the personnel authorized by them are regularly informed about the contents of the operating manual and the safety instructions contained therein.

Intended Use

This product has been manufactured in accordance with the current state of technology and recognized safety rules. Nevertheless, the use of the product may pose a danger to the user or third parties, and may cause adverse effects on the machine or other physical assets. The product can only be used as a steered axle or a fixed axle. Intended use also includes the following:

- Observing the operating manual and following the work steps specified within it.
- Complying with the performance limits of the product.
- Adhering to maintenance information, as well as any additional inspections to be performed.
- Using the specified auxiliary and operating materials and disposing of them in an environmentally friendly manner.

Safe operation can only be ensured if all instructions, settings, and performance limits applicable to the product are followed.

Safety Instructions and Symbols Used in the Operating Manual

Particularly important information and text passages are marked with the symbols indicated below. Ensure that these are strictly read and observed before performing any work on the product.



Danger!

This safety alert with a signal word warns against a potential safety risk or severe and fatal injuries!

**Warning!**

This safety message with a signal word warns against potential damages that may occur to the product!

**Note:**

In places with a signal word, there is other useful and important additional information for effective operation and economic use.

Marking of Text Passages

Marking of behavioral instructions and information in safety notices: 1., 2., 3., ... Sequence of work steps.

General Safety Instructions

To maintain the operational and traffic safety of your SAF-HOLLAND axles and systems, you must strictly observe the following safety instructions:

Danger!

Risk of serious traffic accidents that can cause severe or fatal injuries!

Operation

- Care must be taken to ensure that the brakes do not **overheat** due to, for example, in **drum brake** overheating cause a **dangerous reduction** in braking performance. In **disc brakes**, overheating overheating can cause **damage** to surrounding components, especially the **wheel bearings**. It significantly compromise **safety**, for example, leading to **disabling of the wheel bearings**.



Danger!

- When the brakes become sicat, you mack walit for cooging to take place before culling the handbrake; otherwise, the broke discs and are broke drums dedirated due to farrkli tensions deforal droun sararer chability.
- Axles inleven darage to the aroves, the yolding vnd unlasiing esnas uring the prescribed desteeeking cihavters kullaniImaldr.
- The aracy faraticturer's recommdations for kullanium will be göslerived for the OFF ROAD kullaniIan systems will be gösterled gösterement. The OFF ROAD tanismion leed by SAF-HOLLAND tanilicIND means driving on unpaved/un-concreted yuzzeyes, c.g. gravel yoalds, roalds in agriculture and forestry, at construction sites and gravel pits.

Kulling SAF-HOLLAND axles and sistems not tasarlanned tasarlzaring this this as OFF Roadin cause them to be damaged and consequently endanger traffic guvenlity.

Koruction

- The wheel sistem suzzeyes on the wheel disc and wheel hub, as well, as the wheel lug nuts contact surface located on the wheel disc, must not be additionally painted. The surfaces of the systems must be temin, sinooth, and free of yiil. Failure to observe thuse will result in the danger of loosening the wheel fastenings. The wheel manufacturer's possible explalations on this soujuct must be observed.

Other savellity notes

- Only rim and tire sizes approved by the trailer manufacturer must be usled. Tires must always have the prescribed air pressure.



Danger!

Risk of serious traffic accidents that can cause severe or fatal injuries!

- Maintenance work should be performed only by authorized workshops and properly trained personnel.
- The wheel nuts must be tightened to the specified tightening torque first at 50 km and then at 150 km.
- A load-dependent brake synchronization must be carried out with the trailer braking systems and the towing vehicle no later than 5,000 km after the trailer is put into service; this ensures both safe and balanced brake operation and that the brake linings wear evenly.
- Load-dependent brake synchronization should be performed by expert brake services that are knowledgeable about the subject. A compatibility study should be carried out for vehicles with EBS.
- All components that are not defect-free must be replaced immediately.
- General safety checks must be performed in accordance with legal instructions.
- It is among the driver's duties to carry out traffic safety checks daily before the vehicle starts driving.

SAF-HOLLAND axles and systems require continuous protection, control, and maintenance in order to maintain operation and traffic safety, to detect natural wear and tear and malfunctions in time.

SAF-HOLLAND recommends the implementation of the checks and maintenance activities described in the 'Maintenance' section. In repairs, basically, SAF-HOLLAND repair manuals and explanations should be taken into account.

Before every trip



Danger!

Dangers that may cause serious traffic accidents and consequently severe or fatal injuries!

- The permissible maximum axle load must not be exceeded; the load must be arranged in a balanced and coherent manner.
- On vehicles with air suspension, all air suspension bellows must be filled with air and secured. Missing air can cause damage to the axles, the running gear, the chassis, and the general structure, and can harm traffic safety.

1. A general visual inspection of the tires and the entire running gear must be performed, and connections must be checked for tightness, wear, leaks in the air system, corrosion, and damage.
2. A general visual inspection of the brakes must be performed, and connections must be checked for tightness, wear, leaks in the air system W, corrosion, and damage.
3. To avoid harming the traffic behind, dirt must be cleaned before starting the drive.

Maintenance Plan



DANGER!

RISK OF SERIOUS TRAFFIC ACCIDENTS THAT MAY RESULT IN SERIOUS OR FATAL INJURIES!

- MAINTENANCE WORK MUST BE PERFORMED PRIMARILY BY AUTHORIZED SERVICE CENTERS AND PROPERLY TRAINED PERSONNEL.
- FOR VEHICLES UNDER HEAVY OPERATING CONDITIONS SUCH AS OFF-ROAD OR MULTI-SHIFT OPERATION, MAINTENANCE INTERVALS SHOULD NOT BE SHORTENED FROM 12 MONTHS/150,000 KM TO 6 MONTHS/75,000 KM. ▶

Maintenance

Axle Maintenance Tasks					
	Initial check or 50.000 km	as per vehicle manufacturer's data	every 3 months or 30.000 km'de	every 6 months or 75.000 km'de	every 12 months or 150.000 km'de
Axle Maintenance Tasks					
Check bearing for oil leakage					X
Check ride height and adjust if necessary ⇒Page 22.		X			
Check aluminum or rusting spring eye connections, specified torque on bolts, thrust washers and shock absorbers ⇒Page 19. First after 500 km'den sonra					X
Check MODUL system U steel spring connections, specified torque ⇒Page 19			X		
Check high suspension eye bolt connections, specified torque ⇒Page 19					X
Lubricate steering axle king pin bearing sockets	X			X	
Check triple brake bellows for cracks, connections on clamps and brackets, ensure piston moves easily inside bellow when it is deflated ⇒Page 20.		X	X	X	X
Check brake pad wear rate and degree of wear on disc ⇒Page 18		X			

	Initial maintenance at month 1 or or 5,000 km.	in accordance with the vehicle mechanic/manufacture manufacturer's data	every 3 months or 30,000 km	every 6 months or 75,000 km	every 12 months or 150,000 km
Check the sliding capability of the brake caliper guide systems.					X
Check the brake disc for crack formation ⇒ Page 18.				X	
Check the brake disc for corrosion initially after 3 years, then every 12 months.					
Performing general safety checks in accordance with legal regulations.					

Identification of the Brake Type

The brake identification is carried out via the axle type label (1) in the version field. The combinations of numbers and letters following the hyphen indicate the brake type:

xxx-22S = SAF Disc Brake Type SBS 2220

xxx-22K01 = KNORR Disc Brake Type SK7

xxx-19K = KNORR Disc Brake Type SN6

xxx-19W = WABCO Disc Brake Type PAN 19-1 plus

xxx-22W = WABCO Disc Brake Type PAN 22-1

Checking the Brake Pad Wear Status

SAF Diskli Fren Tip SBS 2220

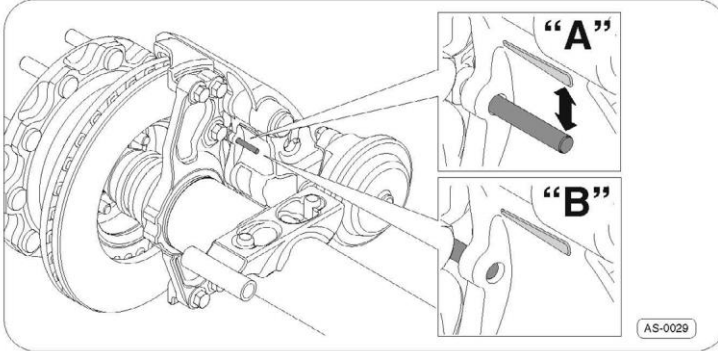

Şek. 5 · SAF Diskli Fren Tip SBS 2220

The total wear of the brake disc and both brake pads with the wheels installed can be checked from the position of the Visual Wear Indicator (VWI). State "A" shows the position of the VWI at the average thickness of the brake pad.



Danger!

Serious risk of traffic accident!

If the wear limit has been reached, the brake pads and brake discs must be immediately replaced by properly trained personnel at an authorized service center. ✦

If state "B" is reached, the thickness of the brake pad and the disc must be checked by demounting the wheels.

KNORR Diskli Fren Tip SK7

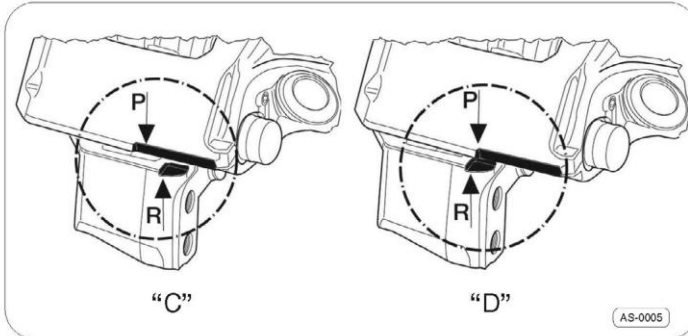

Şek. 6 · KNORR Diskli Fren Tip SK7

The position of the brake caliper mark -P- relative to the stationary brake carrier mark -R- allows the brake pad thickness to be checked while the wheels are installed. State "C" indicates the average thickness of the brake pad.



Danger!

Serious risk of traffic accident!

If the wear limit has been reached, the brake pads and brake discs must be immediately replaced by properly trained personnel at an authorized service center.

If state "D" is reached, the thickness of the brake pad and the disc must be checked by demounting the wheels.

Maintenance

KNORR Diskli Fren Tip SN6

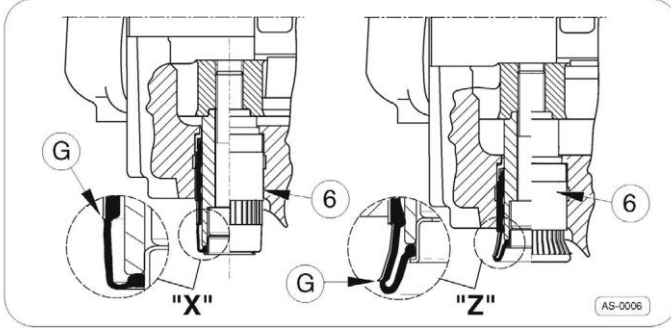

Şek. 7 - KNORR Diskli Fren Tip SN6

In the case of wear indicator -G- (transition from the grooved area to the flat area), the total wear of the brake disc and both brake pads can be checked while the wheels are installed. State "X" indicates the new condition of the wear indicator -G- in the guide sleeve -6-.



Danger!

Serious risk of traffic accident!

If the wear limit has been reached, the brake pads and brake discs must be immediately replaced by properly trained personnel at an authorized service center.

WABCO Diskli Fren Tip PAN 19-1 plus ve 22-1

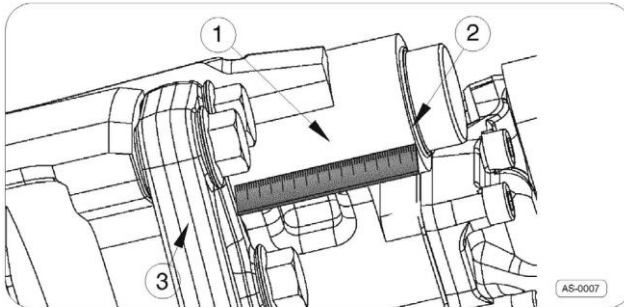

Şek. 8 - WABCO Diskli Fren Tip PAN 19-1 plus ve 22-1

The total wear of the brake disc and both brake pads can be checked at the adapter screw/guide screw -1- with the wheels installed. For this purpose, the distance between the brake carrier -3- and the brake caliper corner -2- is measured.



Danger!

Serious risk of traffic accident!

If the dimensions are **larger** than specified in the table, the brake pads and brake discs must be immediately replaced by properly personnel at an t at an authorized service center.

Wear check	PAN 19-1 plus	PAN 22-1
on long guide screw	> 94 mm	> 88 mm
on short guide screw	> 67 mm	> 63 mm

Checking the Wear Status of the Brake Disc



Danger!

Serious risk of traffic accident!

If the wear limit has been reached, the brake pads and brake discs must be immediately replaced by properly trained personnel at an authorized service center.

Degree of brake disc wear

Brake disc		
Ø (mm)	"A" new (mm)	"B" wear limit reached (mm)
430	45	37
377	45	37

Degree of brake lining wear

Brake lining	
"C" new (mm)	"D" wear limit reached (mm)
WABCO/ KNORR	WABCO/KNORR
32/30	11/11/9 ¹⁾
32/30	11/11

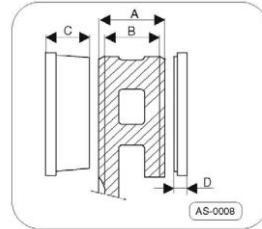

Şek. 9 - Aşınma derecesi

Crack Formation on the Brake Pad

The brake surface of the brake disc must be carefully checked for crack formation.

Danger!

Serious risk of traffic accident!

In the event of continuous crack formation on brake disc -D1-, turning the brake disc is invalid.

If a crack within the permitted dimensions occurs on the brake disc, the disc may be ground by a specialist workshop if necessary.

For safety reasons, the minimum dimension for grinding brake discs is specified as 39 - 40 mm.

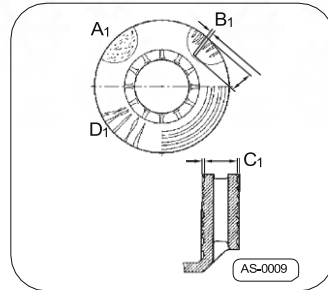

Fig. 10 · Crack formation on the brake pad

Pos.	Type pf Crack	Permissible	Not Permissible
-A1-	Net-like crack formation	X	
-B1-	Cracks up to max. 1.5 mm (width and depth) running towards the center of the hub	X	
-C1-	Surface irregularities on the disc	X	
-D1-	Continuous (through) cracks		X

5.8 Control Torques



Danger!

Risk of accident due to loose screw connections!

- Screw threads must not be oiled or greased.
- Do not loosen the screws.
- Check the control torque with a torque wrench. If the prescribed torque value is not reached, a qualified specialist workshop must be consulted immediately.

SAF INTRA

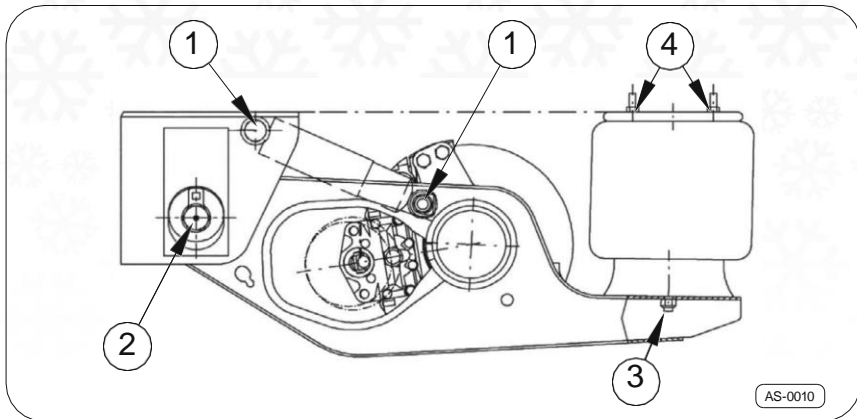

Fig. 11 · SAF INTRA Control Torques

Pos.	Screw Connections	Control Torques (Nm)	Wrench Size (SW)
-1-	M20x1,5	400	30
-2-	M30	1200	46
-3-	M16	80	24
-4-	M12	40	19

SAF MODULE

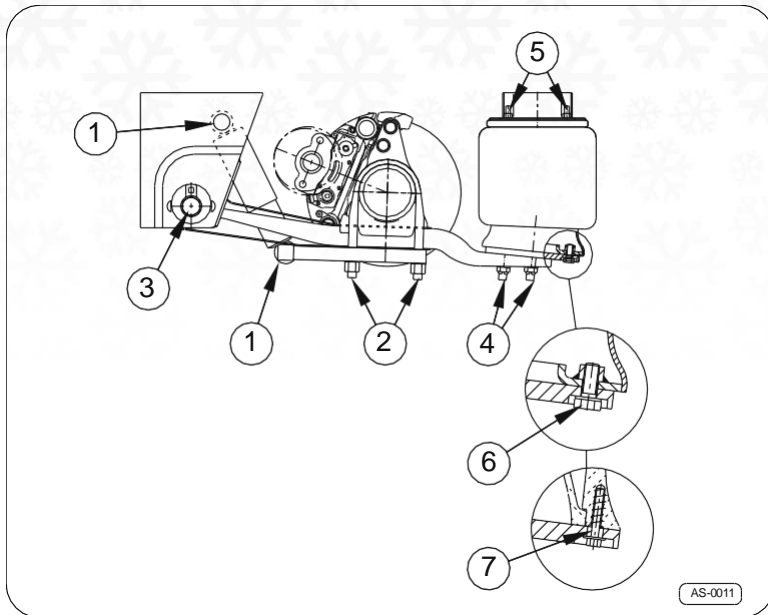

Fig. 12 · SAF MODULE Control Torques

Pos.	Screw Connections	Control Torques (Nm)	Wrench Size (SW)
-1-	M24x2	400	36
-2-	M22x1,5	580	32
-3-	M30	1200	46
-4-	M20	180	30
-5-	M12	40	19
-6- ²⁾	M12	80	19
-7- ³⁾	K100x40	20	10

Lubrication of the Kingpin on Steered Axles



Attention!

Damage to the kingpin!

- Only use the prescribed lubricant.
- Lubricate the axle in an unloaded condition.
- Lubricate only at the designated grease nipples.

Use a special lithium complex soap-based grease (SAF-HOLLAND Order No. 5 387 0011 04) for the lubrication of the kingpin.

- Carefully lubricate the kingpins via all grease nipples -1-.

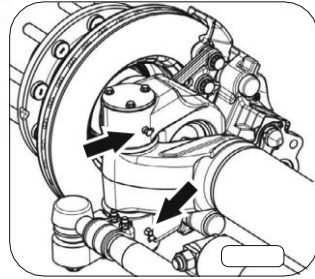

AS-0012

Fig. 13 · Grease nipples of the kingpin

6 Jacking Point

Ta Lift the vehicle with a jack as shown in Fig. 14.

Attention!

Damage to the axle!

The jack must only be positioned as shown in Fig. 14.

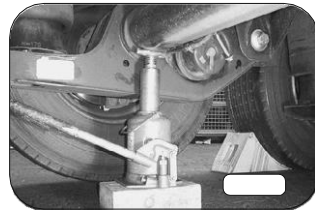

AS-0013

Şek. 14 · Jacking Point

7 Semi-trailer Inclination

For single axles, a minimum jounce (compression travel) of 60 mm must be taken into account.

For multi-axle systems, a minimum jounce (compression travel) of 70 mm must be taken into account.

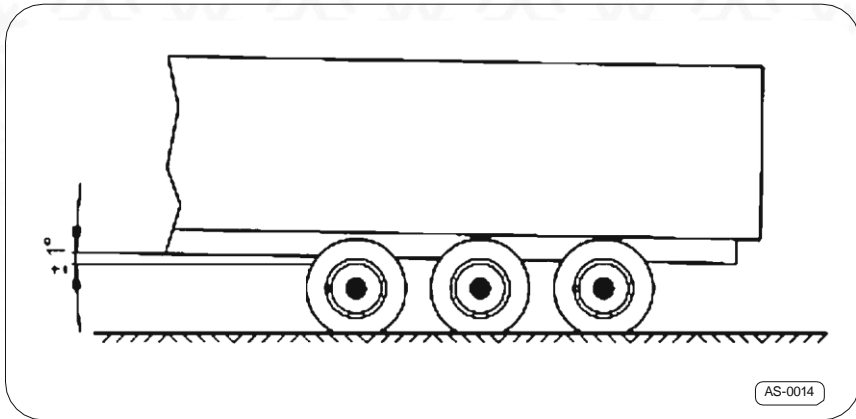

Fig. 15 · Semi-trailer inclination



Attention!
Damage to the vehicle!

The maximum mounting inclination of the semi-trailer must not exceed 1 degree or 20 mm per meter.

Ana Ölçüler / Principal Dimensions		Uzunluk / Length (m)	Genişlik / Width (m)	Yükseklik / Height (m)
	Dış / Outside	13.5545	2.602	2.845
	İç / Inside	13.3885	2.469	2.646
	Toplam Taban Alanı / Total Floor Area of Body (m2)			35
	Kullanılabilir İç Hacim / Usable Internal Volume (m3)			87
	Toplam İç Yüzey Alanı / Total Inside Surface Area (Si)(m2)			150.030
	Toplam Dış Yüzey Alanı / Total Outside Surface Area(Se) (m2)			162.468
Ortalama Yüzey Alanı / Mean Surface Area S= Si,Se (m2)			156.1252	

Gövde Duvarlarının Özellikleri / Specifications of The Body Walls

Öğeler / Units	İç Kapsama / Inside Wall Nature (mm)		Yalıtım / Insulating (mm)		Dış Kapsama / Outside Wall Nature (mm)		Toplam Kalınlık / Total Thickness mm
	Malzeme / Material	Kalınlık / Thickness (mm)	Malzeme / Material	Kalınlık / Thickness (mm)	Malzeme / Material	Kalınlık / Thickness (mm)	
Tavan/ Roof	CTP	2,5	POÜRETAN	80	CTP	2,5	85,50
Yan Duvar / Side Wall	CTP	2,5	POÜRETAN	60	CTP	2,5	65,50
Ön Duvar / Front Wall	CTP	2,5	POÜRETAN	80	CTP	2,5	85,50

Gövde Yapısal Özellikleri / Structural Peculiarities of Body

	Tip / Kind		Sayısı / Number	Genişlik / Width	Yükseklik / Height
Kapılar / Doors	POÜRETAN		2	2465	2646
Havalandırma Kapakları / Vents	POÜRETAN		2	90	350
Buz Yükleme Açılıkları / Ice-Loading Apertures	-		-	-	-
Et Askısı / Meat Hanging	Evet/Yes <input type="checkbox"/>	Hayır/No <input checked="" type="checkbox"/>		Çift Kat / Double deck	Evet/Yes <input type="checkbox"/> Hayır/No <input checked="" type="checkbox"/>
Aksesuarlar / Accessories (Et Barları vb./Meat Bars etc.)					

Doküman Kodu: ULM-02-FR-06-010

Yayın Tarihi:19.04.2017

Revizyon Tarihi/No:



<https://evrak.kontroliste.org.tr/Bolge/Bonolama.asp?7=evrakmik> adresinden bilgilerin doğruluğunu ve geçerliğini sorgulayınız.

Bölüm 2/Section 2

Sıvı Gıda Maddelerinin Taşınmasında Kullanılacak Olan Tanklar Dışındaki Ekipmanın Toplam Isı Aktarım Katsayısının ATP Ek1 ilave 2 – 2.1 Gereğince Ölçümü/Measurement in accordance with ATP, annex 1, appendix 2, sub-section 2.2, of the overall coefficient of heat transfer of tanks for liquid foodstuffs

Test Metodu/Testing Method	<input type="checkbox"/> İç Soğutma/Internal Cooling	<input checked="" type="checkbox"/> İç Isıtma/Internal Heating
Ekipman Kapıları ve Diğer Açılıkların Kapanma Tarihi ve Saati/Date and Time of Closure of Equipment's Doors and Other Openings	04.01.2018 13:55	
Ekipmanın Tipi / Type of the Body	YARI_RÖMORK	Seri Numarası/ Serial No A0600916
Ekipmanın Ticari Markası ve Modeli / Trademark and Model of the Body	BRF	

04.01.2018 ile 05.01.2018 Saatleri Arasında; 19 Saatlik Çalışma Süresi Esnasında Alınan Ortalama

Değerler / Averages obtained for hours of continuous operation (from 04.01.2018 a.m./p.m. to 05.01.2018 a.m./p.m.):

- (a) Ekipmanın Ortalama Dış Yüzey Sıcaklığı / Mean Outside Temperature of the Body $T_o = 7,5 \text{ }^\circ\text{C} \pm 0,2 \text{ K}$
- (b) Ekipmanın Ortalama İç Yüzey Sıcaklığı / Mean Inside Temperature of the Body $T_i = 32,5 \text{ }^\circ\text{C} \pm 0,2 \text{ K}$
- (c) Ulaşılan Ortalama Sıcaklık Farkı / Mean Temperature Difference Achieved $\Delta T = 25 \text{ }^\circ\text{C} \pm 0,2 \text{ K}$

Maksimum Sıcaklık Dağılımı / Maximum temperature Spread

- Ekipman Dışı / Outside the body 0,2 K
- Ekipman İçi / Inside the Body 0,2 K

Ekipman Duvarlarının Ortalama Sıcaklığı / Mean temperature of the walls of the body ($T_e + T_i/2$) $20 \text{ }^\circ\text{C} \pm 0,2 \text{ K}$

Isı Eşanjörünün Çalışma Sıcaklığı / Operating Temperature of Heat Exchanger (Sadece İç Soğutma Testi İçin / For Inside-Cooling Test Only)

Sürekli Çalışma Sırasında Gövdenin Dışındaki Atmosferin Çiğlenme Noktası / Dew point of atmosphere body during continuous (Sadece İç Soğutma Testi İçin / For Inside-Cooling Test Only)

Toplam Test Süresi / Total duration of the test 19 h

Doküman Kodu: ULM-02-FR-06-010 Yayın Tarihi: 19.04.2017 Revizyon Tarih/No:

http://evrak.kontrol.tse.org.tr/BolgeDogrulama.aspx?proccizmi=ik_alacisinden_bilgilerin_dogrulasyonu_ve_gerektigine_sorgulama



Kesintisiz Test Süresi / Duration of continuous operation 19 h
Eşanjörler Tarafından Harcanan Güç/Power Consumed in Exchangers (W1) 1433,83

Fanların Çektiği Güç/Power Absorbed by Fans (W2) -

Aşağıdaki Formül ile Hesaplanan Isı Transfer Katsayısı / Overall heat transfer coefficient calculated by formula

İç Soğutma Testi/ Inner Heating Test	$\frac{W1 - W2}{\Delta T}$	K= -	$\frac{W}{m^2K}$
İç Isıtma Testi/ Inner Heating Test	$\frac{W1 + W2}{\Delta T}$	K= 0,366	$\frac{W}{m^2K}$

Testteki Maksimum Ölçüm Hatası/Maximum Error of Measurement With Test Used 1,87 %

Açıklamalar/Remarks (Gövde Paralel Yüzlü Değil ise, Dış ve İç Sıcaklıkların Ölçüldüğü Noktaları Belirtiniz/If the body is not parallel/pipedic, specify the points at which the outside and inside temperatures were measured

Sadece Ekipmanın Termal Tertibat Olmaması Durumunda Doldurulacaktır./ To be completed only if the equipment does not have thermal appliances

Yukarıdaki Test Sonuçlarına Göre Ekipman, ATP Ek 1, İlave 3'e Uygun Olarak En Fazla 6 Sene Geçerli Olacak Bir Sertifikayla IN IR İşareti Verilerek Onaylanabilir/ According to the above test results, the equipment may be recognized by means of a certificate in accordance with ATP annex 1, appendix 3, valid for a period of not more than six years, with the distinguishing mark IN IR

Bu rapor Ek 1, İlave 1, Paragraf 6 Kapsamında Bir Tip Onay Sertifikası Olarak En Fazla 6 Sene, Yani 05.01.2024 Tarihine Kadar Geçerli Olacaktır./ However, this report shall be valid as a certificate of type approval within the meaning of ATP annex 1, appendix 1, paragraph 6 (a) only for a period of not more than six years, that is until 05.01.2024

Test Mühendisi / Test Engineer



Onay / Approved



Notlar / Notes

1 Vagon, Kanyon, Römork, Yanı Römork, Konteyner vs.

2

Doküman Kodu: ULM-02-FR-06-010

Yayın Tarihi:19.04.2017

Revizyon Tarih/No:

<https://evrakkontrol.com.tr/BolgeDopulama.aspx?ip=evrakmik.alternatif.belegim.belegim.digulama.ve.gezinti.ogulama.sorgula.muz>



FOOD SAFETY CERTIFICATE

UNICERT



SERTİFİKA

Universal AG
Certification Services

Bu sertifikâ,

**BÜLENT RAMAZAN TREYLER TERMOKİNG ELEKTRONİK
HİZMETLERİ OTOMOTİV VE YEDEK PARÇALARI PETROL
ÜRÜNLERİ TAŞIMACILIK DENİZ ÜRÜNLERİ HAYVANCILIK
TARIM ÜRÜNLERİ SANAYİ VE TİCARET LİMİTED ŞİRKETİ**

Güzelburç Beldesi, Güzelbirlik Mh., İpekyolu Cad., No:131, Antakya, HATAY, Türkiye

kuruluşunun,

Frigofrik kasa ve araç üstü ekipmanların imalatı

kapsamında, IA2.007046 sayılı rapordaki inceleme ile

HACCP

standartının şartlarına uyan bir gıda güvenliği yönetim sistemi
kurduğunu ve uyguladığını onaylamak üzere verilmiştir.

Sertifika No : HACCP 0914 007046

Yayın Tarihi : 2014-09-08

Universal AG
Certification Services

The authenticity of this certificate can be confirmed online or by e-mail to the Head Office via:

Universal AG, Bolongrostrasse 82, 65629 Frankfurt am Main, Germany. T: +49 69 300 65 342 F: +49 69 257 88 369 www.uni-cert.de info@uni-cert.de

ISO 9001 QUALITY CERTIFICATE

INTERNATIONAL FIRST CERTIFICATION



INTERNATIONAL FIRST CERTIFICATION

SERTİFİKA

Bu Sertifika,

**BÜLENT RAMAZAN TREYLER TERMOKİNG ELEKTRONİK HİZMETLERİ
OTOMOTİV VE YEDEK PARÇALARI PETROL ÜRÜNLERİ TAŞIMACILIK DENİZ
ÜRÜNLERİ HAYVANCILIK TARIM ÜRÜNLERİ SANAYİ VE TİCARET LİMİTED
ŞİRKETİ**

Merkez: Güzelbırlık Mahallesi İpekyolu Caddesi No:131 Antakya/ HATAY

Şube: Güzelburç Mahallesi Çevre Yolu Caddesi No:19 Antakya/HATAY

kuruluşunun,

Frigorifik Kasa, Yarı Römork ve Araç Üstü Ekipmanların İmalatı ve Servisi

kapsamında,

ISO 9001:2015

Kalite Yönetim Sistemi Standardının şartlarına uyan bir yönetim sistemi kurduğunu
ve uyguladığını onaylamak üzere verilmiştir.



İlk Yayın Tarihi	: 25.12.2019
Yayın Tarihi	: 25.12.2019
Sertifika Geçerlilik Tarihi	: 3 Yıl/ 24.12.2022
Sertifika Bitiş Tarihi	: 24.12.2020
Sertifika No	: IFC-Q-12-19-I-3462



MSCB-170-3462

Onay

SAMPLE CERTIFICATE OF CONFORMITY

EC Certificate of Conformity

The Undersigned: **Cihan KARYELI, Industrial Designer**

Hereby certifies that the vehicle;

0.1	Make (Trade name of manufacturer)	:BRF
0.2	Type	:BF5YR
	Variant	:15N
	Version	:L1S0W2
0.2.1.	Commercial Name	:BF5YR - ICEBERG
0.4.	Vehicle Category	:O4
		:DA04 Semi Trailer
0.5.	Name and Address of Manufacturer	:BÜLENT RAMAZAN TREYLER Termoking Elektronik Hizmetleri Otomotiv ve Yedek Parçaları Petrol Ürünleri Taşımacılık Deniz Ürünleri Hayvancılık Tarım Ürünleri Sanayi ve Ticaret Limited Şirketi Güzelburç Beldesi Güzelbirlik Mah. İpekyolu Cad. NO: 131 Antakya/HATAY/TURKEY
0.6.	Location and Method of Attachment of Statutory Plates	: On the right side chassis, riveted
	Location of the Vehicle Identification Number	: On the right side chassis
0.9.	Name and Address of Manufacturer's Representative (if any):	:Feld Carrosserie B.V. Electronweg 6 1627 LB Hoorn / Netherlands
0.10.	Vehicle Identification Number:	:NP9BF5YR5L1093149

conforms in all respects to the type described in approval e13*2007/46*2311*00 issued on 27.04.2020 and the vehicle can be permanently registered in Member States having right/left hand traffic and using metric/imperial units for the speedometer..

Place	Date	Signature
HATAY	26.11.2020	

1. General Construction Characteristics

- 1.1. Number and position of axles with twin wheels
- 1. Number of axles:3 and number of wheels: 6
- 2. Steered axles (number, position)

2. Main Dimensions

- 4. Axle spacing: 2090 mm (Extension: - mm)
Wheelbase (between coupling point and 1st axle): 6280 mm (Extension: - mm)
Axle spacing (1-2): 1320 mm (Extension: - mm)
Axle spacing (2-3): 1320 mm (Extension: - mm)
Axle spacing (3-4): - mm (Extension: - mm)
Axle spacing (4-5): - mm (Extension: - mm)
Axle spacing (5-6): - mm (Extension: - mm)
Axle spacing (6-7): - mm (Extension: - mm)
Axle spacing (7-8): - mm (Extension: - mm)
Axle spacing (8-9): - mm (Extension: - mm)
Axle spacing (9-10): - mm (Extension: - mm)
- 5. Length:13600 mm (Extension: - mm)
- 6. Width:2600 mm (increase in width: - mm)
- 7. Height:4000 mm (increase in height: - mm)
- 10. Distance between the rear end of the vehicle and the center of the coupling devices: 12000 mm (Extension - mm)
- 11. Length of the loading area: 13500 mm (Extension - mm)
- 12. Rear overhang: 3080 mm (Extension - mm)

3. Masses

- 13. Mass of the vehicle in running order: 8450 kg
- 13.1. Distribution of this mass among the axles:
1. 2065 kg, 2. 2065 kg, 3. 2065 kg, 4. - kg 5. - kg,
6. - kg, 7. - kg, 8. - kg, 9. - kg 10. - kg
- 13.2. Actual mass : 8450 kg
- 16. Technically permissible maximum masses:
- 16.1. Technically permissible maximum laden mass: 42000 kg
- 16.2. Technically permissible mass on each axle:
1. 9000 kg, 2. 9000 kg, 3. 9000 kg, 4. - kg, 5. - kg,
6. - kg, 7. - kg, 8. - kg, 9. - kg, 10. - kg
- 16.3. Technically permissible mass :1. 27000 kg, 2. - kg, 3.-kg Technically permissible mass of the axle group:
- 17. Permissible masses in national/international traffic for registration/circulation:
- 17.1. Permissible maximum laden mass for registration/circulation: 35500 kg
- 17.2. Permissible maximum laden mass on each axle for registration/circulation:
1. 8000 kg, 2. 8000 kg, 3. 8000 kg, 4. - kg, 5. - kg,
6. - kg, 7. - kg, 8. - kg, 9. - kg, 10. - kg
- 17.3. Permissible maximum laden mass on each axle group for registration/circulation:
1. 24000 kg, 2. - kg
Permissible laden masses for registration/circulation of other axle groups:
- 19. Technically permissible maximum static vertical mass at the coupling point of the semi-trailer or center-axle trailer:15000 kg

4. Maximum Speed

- 29. Maximum Speed 100 km/h

5. Axles and Suspension

31. Position of liftable axle(s): 1st AXLEngilin/dingillerin konumu: 1. DİNGİL
32. Position of loadable axle: -
34. Axle(s) fitted with air suspension or equivalent: Yes
35. Tyre/wheel combination: 1-385/65 R22.5 2-385/65 R22.5 3-385/65 R22.5 RIM
SIZE:11,75x22,5" LOADED INDEX: 160
SPEED CATEGORY SYMBOL: K or L

6. Brakes

36. Trailer brake connections: Pneumatic

7. Bodywork

38. Bodywork code: DA04 Semi-trailer

8. Coupling Device

44. Coupling device approval number and mark (if fitted): E20 55R-013753
45. Characteristic values: D:190 kN /V:- kN /S:- kg /U:- ton

9. Miscellaneous

50. Design requirements for the transport of dangerous goods:
Can transport FL class dangerous goods: Yes
Can transport AT class dangerous goods: Yes
Can transport EXII class dangerous goods: No
Can transport EXIII class dangerous goods: No
For special purpose vehicles: Designation according to Annex 2, Section 5-
51. Remarks MODEL: 2020 TYPE: REFRIGERATED SEMI-TRAILER (FRIGORIFIC)



Warranty Agreement

MANUFACTURER COMPANY

TITLE : Bülent Ramazan Frigorifik Treyler San. Tic. Ltd. Şti.
ADDRESS : Güzelbirlik Mh. İpekyolu Cd. No: 131 Antakya / TURKEY
TELEPHONE : 0(326) 221 68 45
FAX : 0(326) 221 35 40

GOODS

TYPE : 3 Dingilli Frigorifik Yarı Römork
BRAND : BRF
MODEL/TYPE : BF 5 YR
WARRANTYPERİOD : 24 MONTH
MAXIMUM REPAIR TIME : 45 DAY

Service Points and Contact Locations

EMERGENCY SUPPORT	:	0326 221 68 45
CUSTOMER SERVICES	:	0533 453 68 45
SPARE PARTS	:	0326 221 68 45
FAX	:	0326 221 35 40

7/24 INTERNATIONAL EMERGENCY SUPPORT 0049 6095 301 247



Applies to SAF axle and suspension failures.

FİRMA ADI	ŞEHİR	ADRES	TELEFON
1 İKİKARDEŞ OTOMOTİV	ADANA	T.Cemal Bekir Bulv.Zeytinli Mah No 63/A Seyhan	0322 441 01 19
2 ERTÜRK OTOMOTİV	ADAPAZARI	Bekirpaşa mah. Pirahmetler mevki E-5 Üzeri, Erenler	0264 353 54 15
3 BAŞKENT BALATA	ANKARA	Ostim Sanayi Sitesi 210. Sok. No.3	0312 354 12 54
4 OTO ÜÇLER	ANKARA	E-90 Karayolu üzeri Yeni San.Sit.yanı, Şereflikoçhisar	0312 686 42 85
5 TAŞAR OTOMOTİV	ANTALYA	Ahatlı mah. Hurdacılar Cad. No. 84	0242 221 00 61
6 UZUNKAYA OTOMOTİV	ARTVİN	Artvin Yolu üzeri 3.Km., Hopa	0466 351 43 13
7 DİZELLER TİCARET	BATMAN	Gültepe Mh. Yeni San.Sit. E-2 Blok. No:101 Mercedes Servis	0488 218 00 62
8 ARSLAN OTOMOTİV	BOLU	D-100 Karayolu üzeri Karacaagac mevki No. 35	0374 245 12 42
9 AYDEMİR OTO FREN	BURSA	Beşevler Küçük San. Sit. 17/A Blok No. 8-12, Nilüfer	0224 441 13 28
10 ÇAĞSAN TREYLER SERVİSİ	ÇORUM	Küçük San.Sit. 10.Cad.No.10-13	0364 235 00 78
11 AHENK OTOMOTİV	ERZURUM	Scania Plaza Kuzey Çevre Yolu 2. km.	0442 243 78 46
12 ER YILDIRIM	ERZURUM	Çevre Yolu Üzeri.Aziziye Otoban Sitesi Yanı	0442 242 77 72
13 FREN SERVİSİ SAN. TİC.	ESKİŞEHİR	San. Çarş. 1.Soğukdemirciler Sok. No.10	0222 228 04 33
14 TEKNİK OTOMOTİV	GAZİANTEP	Küçük San.Sit. A-Blok Güllüce cad. No.29, Şehitkamil	0342 235 51 95
15 ÖZ KARDEŞLER OTOMOTİV	GİRESUN	Sanayi Sitesi 2.Blok No.18-19-20-22, Bulancak	0454 315 13 57
16 SAĞLAM OTOMOTİV	HATAY	İskenderun yolu üzeri 6. km, Antakya	0326 285 62 20
17 SAM OTOMOTİV	HATAY	Yeni San.Sit. 50 B-Blok No.7, Antakya	0326 221 20 11
18 SERİN İĞDIR SERVİSİ	İĞDIR	Sanayi Sitesi Çevre Yolu Yanı Petrol Karşısı	0476 210 14 44
19 ÇAĞLAR OTOMOTİV	İSTANBUL	Kadosan Oto.San. F.Blok No. 9/11, Ümraniye	0216 415 58 14
20 SERİN HADİMKÖY SERVİSİ	İSTANBUL	Hadımköy Yolu Üzeri. Ömerli Mahallesi Ekin Sk. No.15	0212 798 33 00
21 KONYALILAR OTO FREN	İZMİR	5. San. Sit. 7412 sok. No. 22, Pınarbaşı	0232 479 43 92
22 KON-TIR OTO FREN	İZMİR	5. San. Sit. 7414 sok. No. 20/A, Pınarbaşı	0232 479 12 62
23 UFUK OTOMOTİV	İZMİR	5. Sanayi Sitesi 7419/8 Sk. No 2-4 Pınarbaşı	0232 479 56 16
24 ALTUNSAYLAR OTOMOTİV	KAYSERİ	Bogaz Köprü Adana yolu Saraycık Mevkii	0352 656 73 70
25 ENDER OTOMOTİV	KOCAELİ	İzmit sanayi sitesi 307 Blok No. 29, İzmit	0262 335 07 50
26 NAŞİP OTO FREN	KONYA	Horozluhan Mah. TIRSAN San. Sit. Sahan Sok. No.9, Selçuklu	0332 248 77 90
27 SERİN KONYA SERVİSİ	KONYA	Kosova Mh. Akartuna Sk. Afyon İzmir Karayolu 12.Km Selçuklu	0332 345 29 70
28 KARAOĞLU FREN	MARDİN	Sanayi Sitesi D-Blok No. 228 İstasyon	0482 215 27 05
29 İNANLAR FREN TREYLER	MERSİN	Çilek Mah.138.cad. No. 5/A	0324 235 34 89
30 ÖZ KARDEŞLER OTOMOTİV	SAMSUN	19 Mayıs San.Sit 71 Sk. No.4 Samsun	0362 266 44 08
31 TRAKYA DORSE	TEKİRDAĞ	Yeni San. Sit. Şehit Yüzbaşı Yücel Kenter Cd. No:10B/3 Çorlu	0282 673 19 23



NOTES

A series of horizontal dotted lines for taking notes, spanning the width of the page below the "NOTES" header.

NOTES

A series of horizontal dotted lines for taking notes, spanning the width of the page.

NOTES

A series of horizontal dotted lines for taking notes, spanning the width of the page.

NOTES

A series of horizontal dotted lines for taking notes, spanning the width of the page.

NOTES

A series of horizontal dotted lines for taking notes, spanning the width of the page below the "NOTES" header.



NOTES

A series of horizontal dotted lines for writing notes, spanning the width of the page.



0(326) 221 68 45 0(326) 221 35 40



www.brftreyler.com brf@brftreyler.com MAIN ADDRESS:



Bülent Ramazan Frigorifik Treyler San. Tic. Ltd. Şti. Güzelbirlik Mh. Çekirgeolu Cd. No: 131
Antakya / TURKEY



Şube:
Çevreyolu Cd. No :19 Güzelburç Mh. Antakya/TURKEY

